

PV-ezRack
SolarTerrace Eco (EU)
Installation Guide
NO.: PZ046-IM04-10

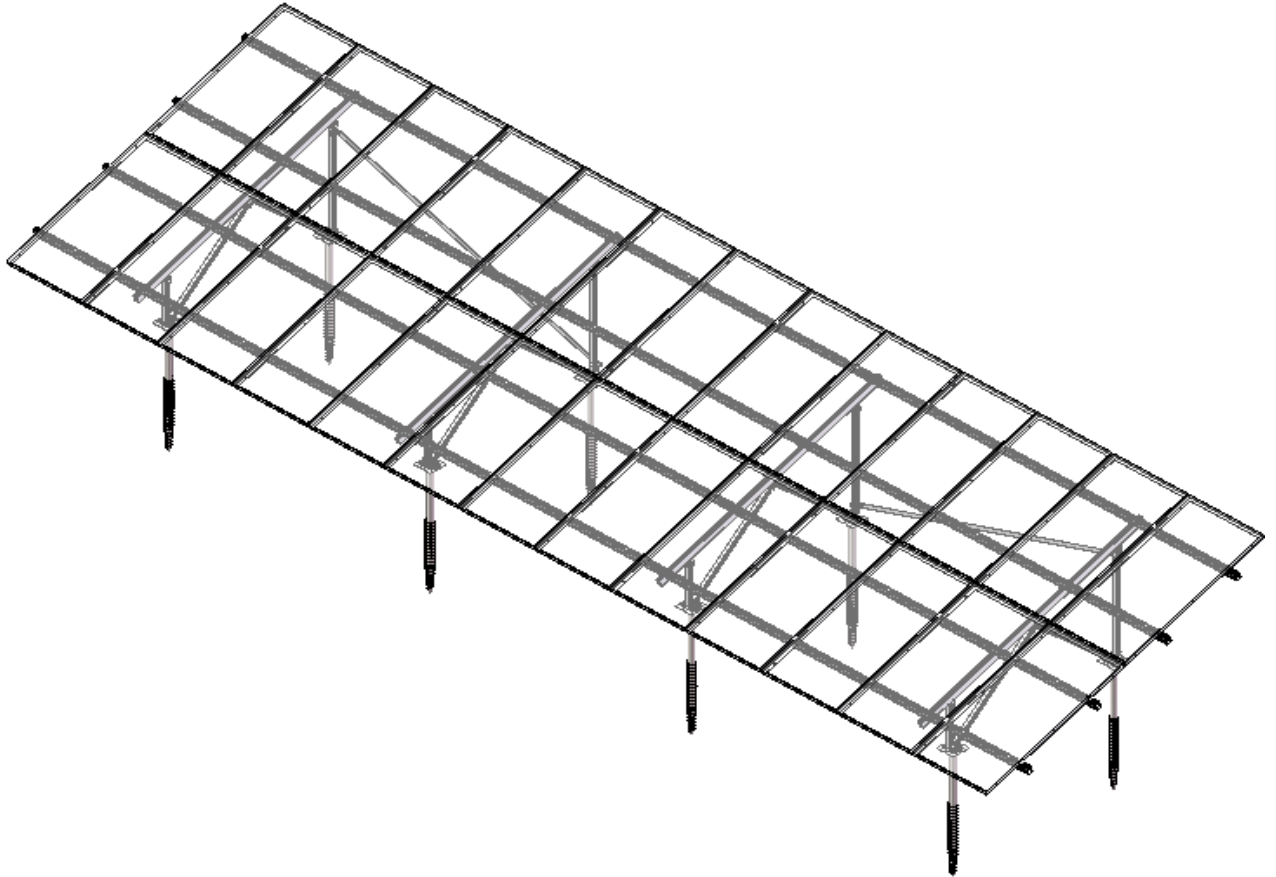

Content

1. Production Introduction	2
2. Tools & Components	3
3. System Overview	7
4. Installation Instructions	9

1. Production Introduction

Cleenergy PV-ezRack®SolarTerrace Eco (hereinafter referred to as ST Eco) is a pre-assembled ground PV-Module mounting system, which is suitable for large-scale commercial installation and multi-purpose installation. ST Eco has been developed as a mounting system for various PV-module. Innovative and unique Rail with M Module is convenient and helps to improve the installation precision. Using high quality engineered components SolarTerraceEco more suitable for areas with higher salinity, and saves developers and installers, time and money when delivering large scale projects.

Before system installation, please read the installation instruction manual carefully. The manual provides the following content: (1) simple introduction of installation; (2) product installation specification;









Please use it according to the installation instruction manual, which complies with GB50009-2012, JIS 8955-2017, ASCE7-10, ISO 14713 and other building codes. Please pay attention to safety when installing the product, and construct it according to local laws and regulations. You can confirm the latest installation instruction manual on www.cleenergy.com.cn if necessary.

Installation personnel shall conform to the following specifications

- Conform to all local or national construction specifications that can replace the manual;
- Guarantee that Cleenergy mounting products are applicable to specific installation and installation environment;
- Please use Cleenergy's accessories and your installation tools. (Cleenergy will be not liable to other accessories that replace Cleenergy's ones);
- Recycle according to local related laws;
- Disassembly is corresponding to installation steps;
- The number of solar plate installation personnel shall be not less than 2;
- Guarantee that installation of electric equipment is finished by professional electricians.



2. Tools & Components

2.1 Tools

Tools			
			
Allen Key 6mm (M8 Hexagon Socket Screw)	Socket Wrench M8/M12	Torque Wrench	Electric Drill
			
5m Tape	Marker	String	Total Station or Equivalent device
			
Pile Driver			

Note: The tools in the figure are only used for installation of rack system (not included in supply scope). Please consult system installation personnel about installation of electronic parts.

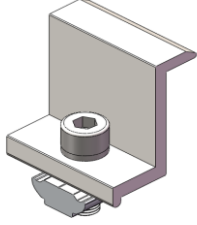
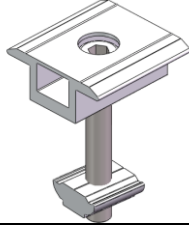
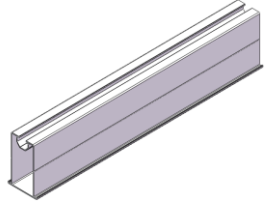
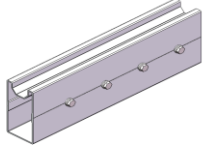
2.2 Components

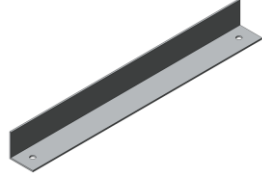
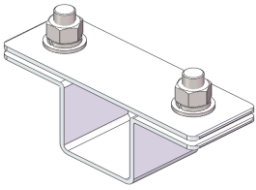
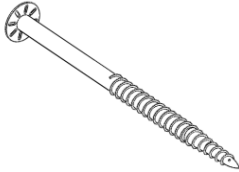
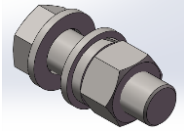
Components		
		
EC-W/A End Clamp	ICII-W/A Module Inter Clamp II	R-TW TW Rail
		
SP-TW Splice for TW Rail	S-Eco/W Support	ER-AA Angle AL
		
CO-RT Connector for Rectangular Tube	GS Ground Screw	ER-HB-ST Hexagonal Bolt MXX*XX (with nut and washer)

2.3 Installation Precautions

2.3.1 Stainless Steel Fastener Installation Precautions

Improper operation may lead to deadlock of Bolts and Nuts. Follow the steps below to reduce this risk

- Reduce the friction coefficient:
 - (1) Ensure that the thread surface is clean (no dirt or contaminant)
 - (2) Apply lubricant (grease or 40# engine oil) to fasteners prior tightening to avoid galling or seizing in the threads;
- General installation instructions:
 - (1) Apply force to fasteners in the direction of thread;
 - (2) Apply force uniformly, to maintain required torque;
 - (3) Professional tools and tool belts are recommended;
 - (4) Avoid using electric tools for final tightening;
 - (5) Avoid working at high temperatures,
- Safe Torques

Please refer to safe torques defined in this guide as shown in below figure. In case power tools are required, Cleenergy recommends the use of low speed only. High speed and impact drivers increase the risk of bolt galling (deadlock) If deadlock occurs and you need to cut fasteners please make sure that there is no load on the fastener before you cut it. Avoid damaging the anodized or galvanized surfaces.

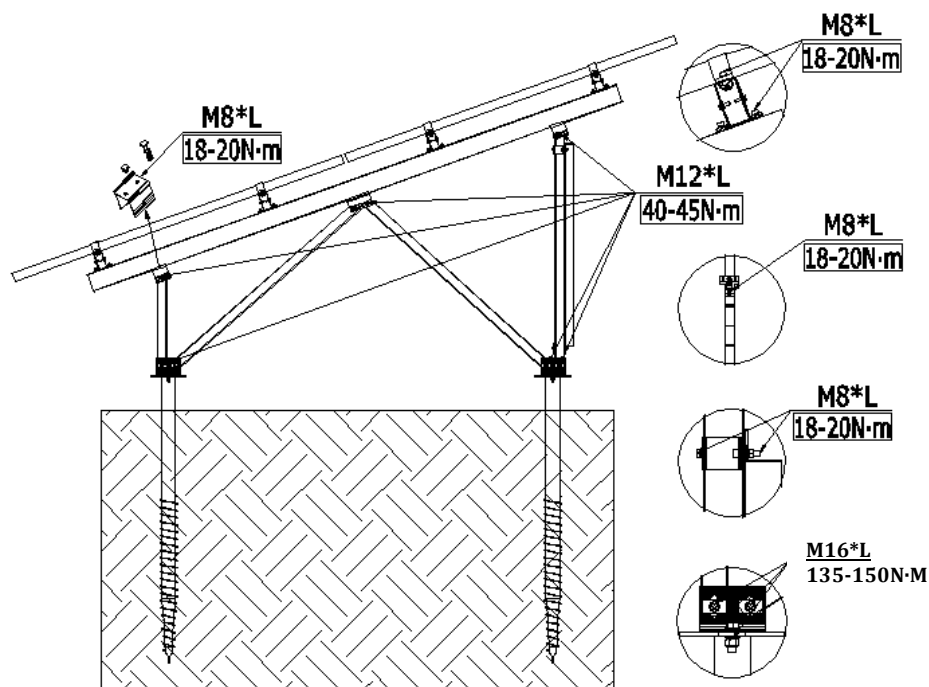

2.3.2 Ground Screw Installation Precautions

All ground screws for the projects are hot dipped galvanized to offer good look and reliable corrosive resistance, please pay attention to below tips:

- In order to protect the Zin coating of ground screws from scratches and peeling. Please be careful while unloading.
- In order to protect the ground screws from coating wear and structural deformation, DO NOT pile the ground screws forcefully while there are large rocks.
- Please apply Zin-rich paint on the surface of ground screws if necessary. And Clenergy will not be liable to the scratches and peeling on the coating surface of ground screws that caused by improperly unloading and piling in the construction site.

3. System Overview

3.1 Composition

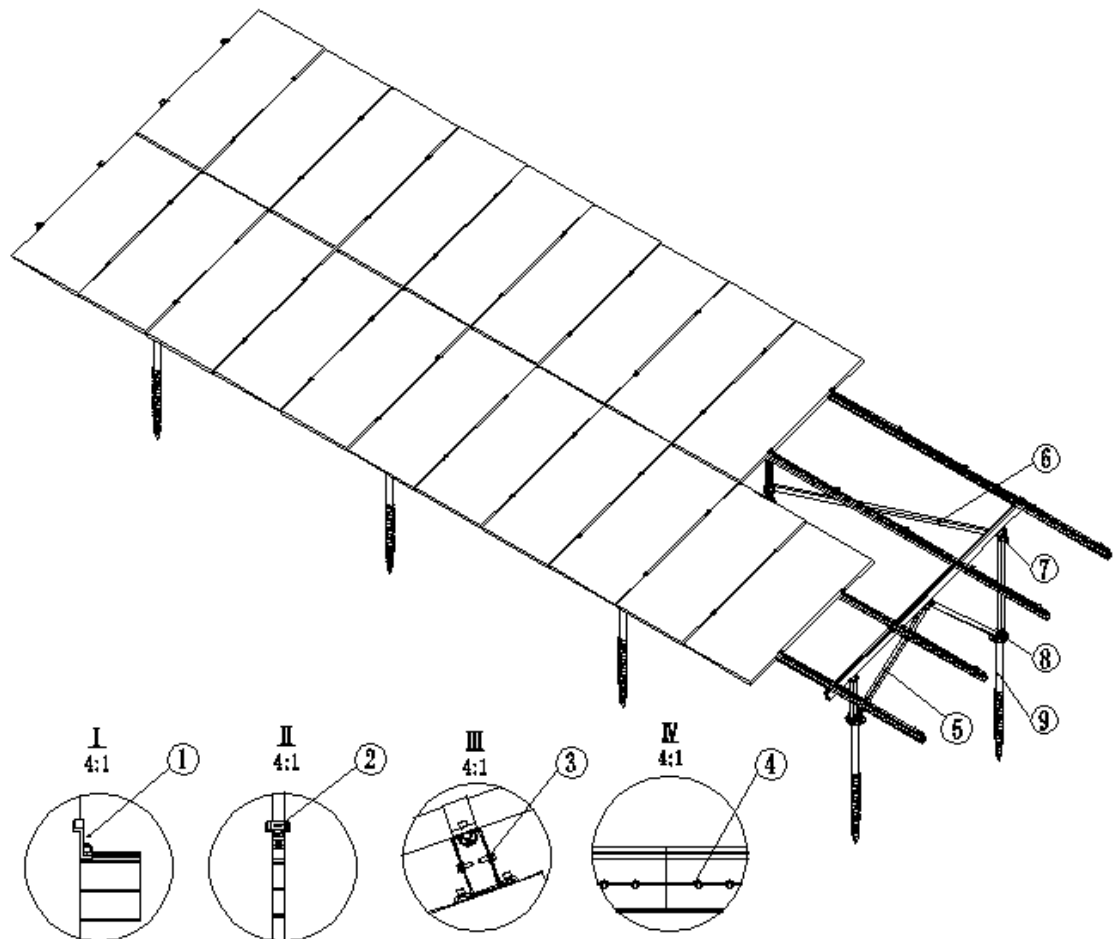

- 1) End Clamp with W Module
- 2) Module Inter Clamp II
- 3) TW Rail
- 4) Splice for TW Rail
- 5) Support
- 6) Angle AL
- 7) Connector for Rectangular Tube
- 8) Hexagonal Bolt MXX*XX (with nut and washer)
- 9) Ground Screw

3.2 Installation Planning

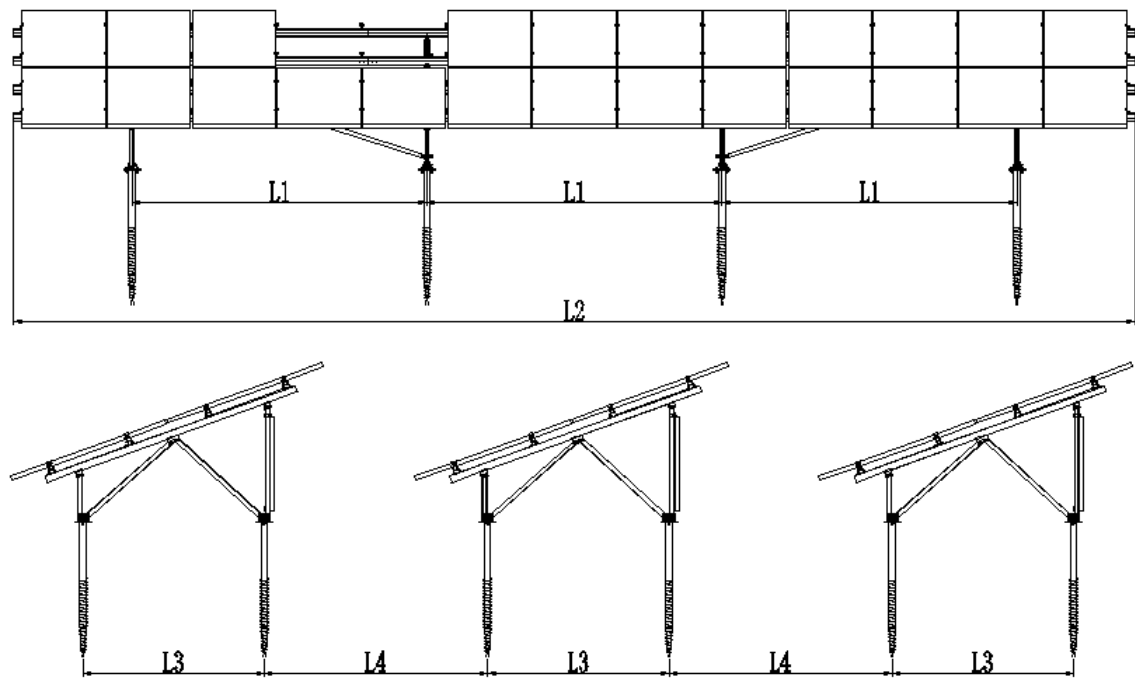

- 1) PV Module Orientation: Portrait
- 2) Rail Length per table: L2 according to engineering drawings
- 3) Distance between the two adjacent supports: L1 according to engineering drawings
- 4) Distance between two legs: L3 according to engineering drawings
- 5) Distance between two tables: L4 according to engineering drawings

4. Installation Instructions

4.1 Ground Screw Installation

4.1.1 Before the installation, please prepare necessary installation tools & products, and ensure that hydraulic pile driver can work normally in installation site. Read the relevant engineering materials; get the project layout information such as piling depth, column span, etc. If you have any questions, please contact and consult the customer service.

4.1.2 According to the installation planning, use Total station (or any instrument of similar functions) to carry out positioning mark and mark out the piling position of each ground screw. Check the mark position before piling, to ensure accuracy.

4.1.3 Make necessary adjustment to make sure that all ground screw are on the same level and are all aligned.

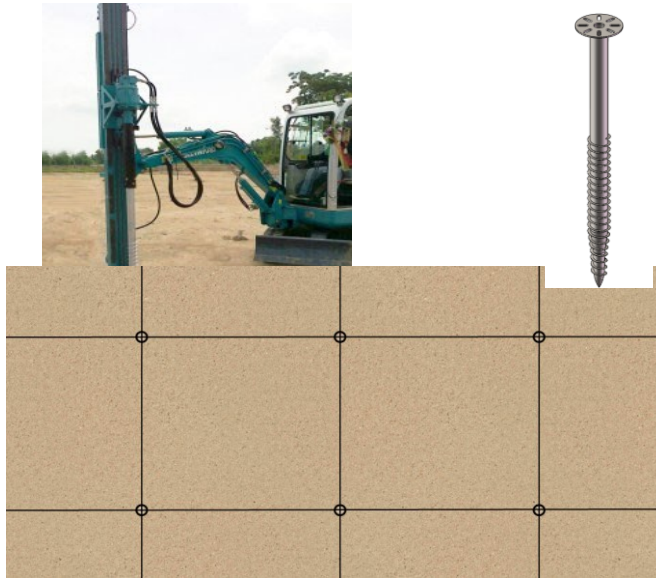

Piling depth, horizontal and vertical position of Ground screws are determined by the engineering drawings of specific projects

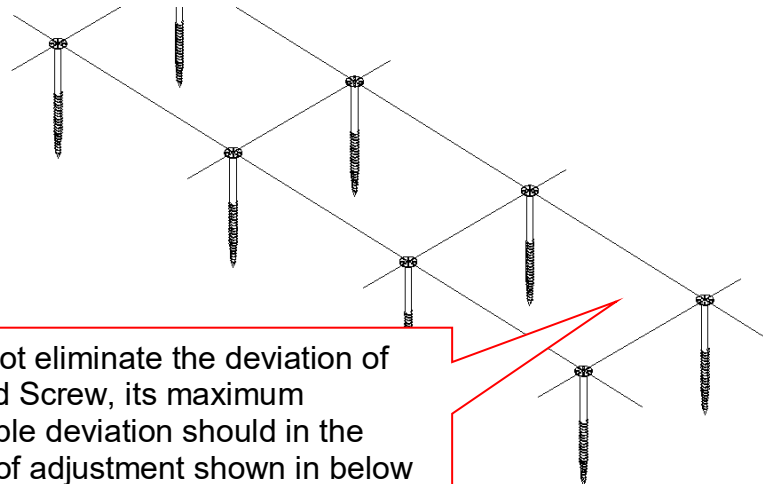

If cannot eliminate the deviation of Ground Screw, its maximum allowable deviation should in the range of adjustment shown in below Figure 7.

Figure 2

4.2 Pre-assembled Support Installation

4.2.1 Before installing Pre-assembled Support, check the ground screws are on the same level and are all aligned.

4.2.2 Before installation, it looks as shown Figure 3.

Unfold the Rectangular Tubes as shown in Figure 4.

Unlock the M12*85 Bolts from the Slot U-Shape Joint. Insert the end of 2 free end Rectangular Tubes into the Slot U-Shape Joint. Lightly lock them with M12*85 Bolts. Here, please note the orientation of the 2 sets of bolt; make sure their head are in the same side with other bolts. Rotate the Corrugated L-anchor Plates to make them in a same horizontal level, as shown in Figure 6.

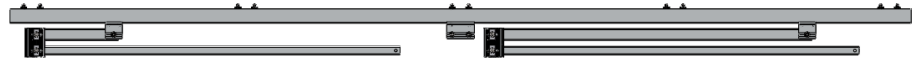

Figure 3

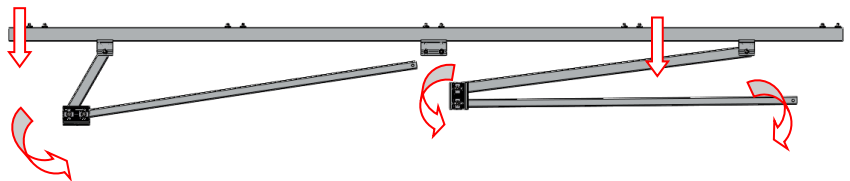

Figure 4

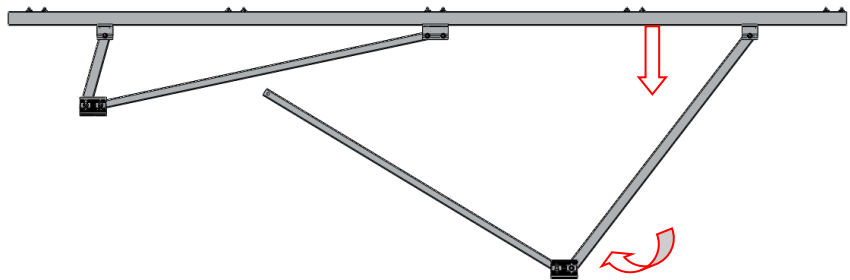

Figure 5

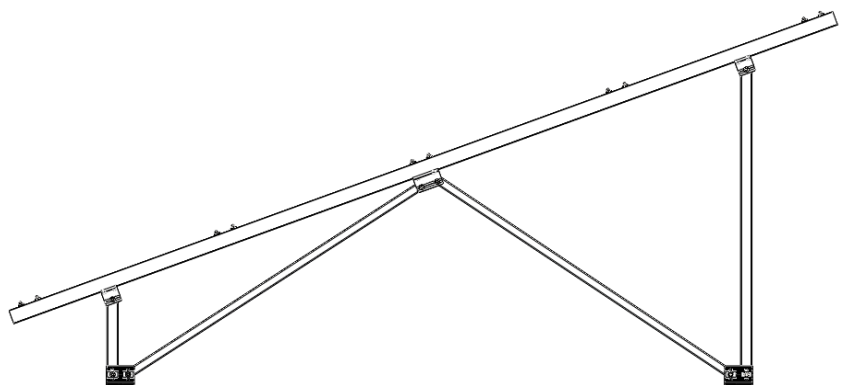

Figure 6

4.2.3 Put the unfolded Pre-assembled Support on flange plates of Ground Screws and lock the L-anchor Plates with flange plates with M16 bolts. The up-down adjustable range of Front/Rear leg is $\pm 20\text{mm}$. The north-south adjustable range of Front/Rear leg is $\pm 30\text{mm}$. the East-west adjustable range of Front/Rear leg is $\pm 20\text{mm}$ as shown in Figure 7

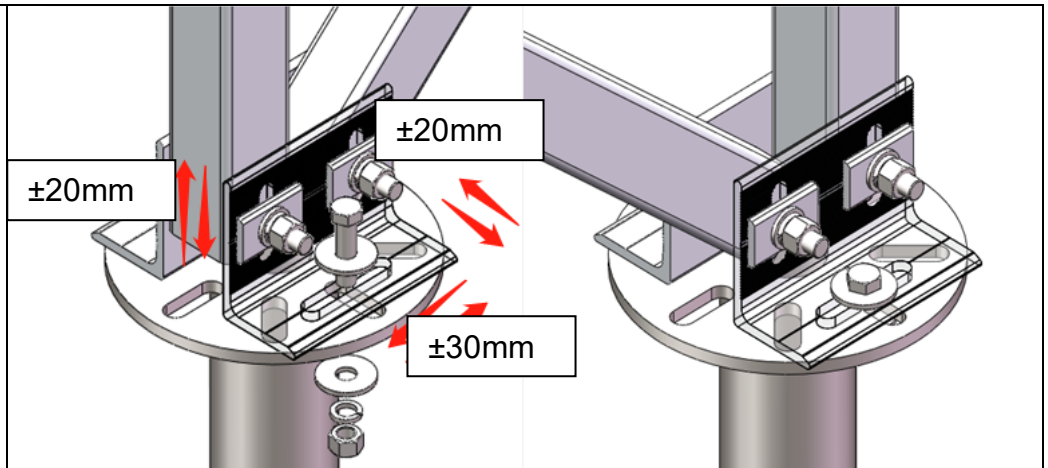

Figure 7

4.2.4 Fasten all bolts according to the torque. Check all bolts and ensure they are fastened within recommended torque.

Recommended Torque:

M8: 18~20 N·m

M16: 135~N·m

4.2.5 According to engineering drawings, repeat the above operations to install other Pre-assembled Supports. Ensure all the Two-Groove Square Girders of Pre-assembled Support are aligned and all Pre-assembled Support are parallel to each other. Unlock M12 bolts to adjust the position, if necessary, as shown in Figure 8.

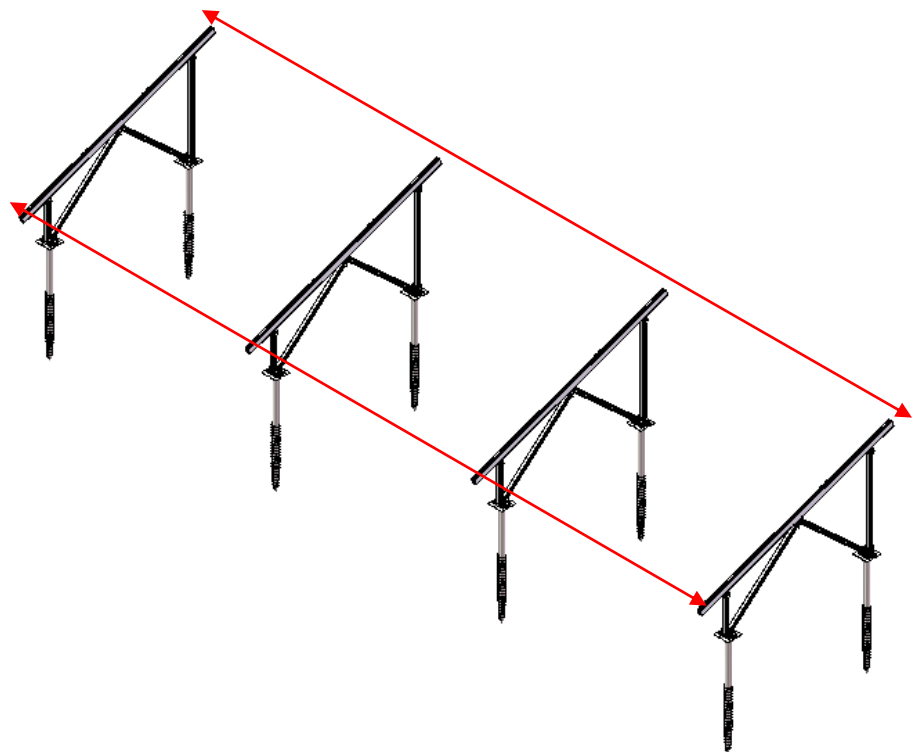

Figure 8

4.3 Rail Installation

4.3.1 Before fix TW Rails on the Support, splice them to the required length with Splice for TW Rail.

Insert half of Splice into TW Rail and fasten with two sets of Self-tapping screws ST6.3*22 in each side of TW Rail, and then insert the other Splice into TW Rail and fasten with Self-tapping screws as shown in Figure 9.

NOTE: Please fasten the Self-tapping screws until its rubber washer attach the TW Rail tightly.

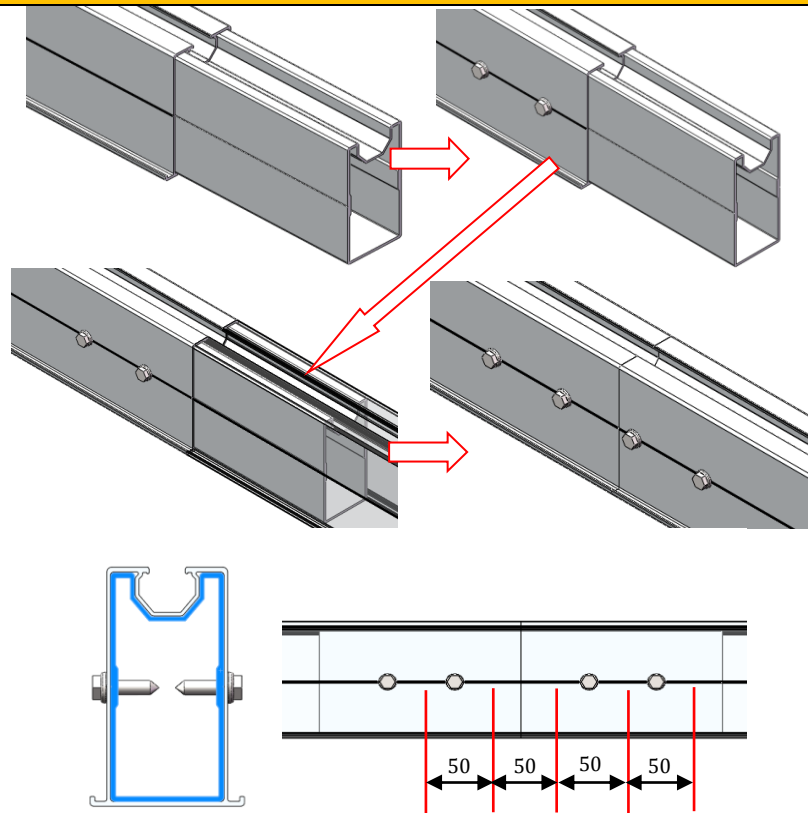
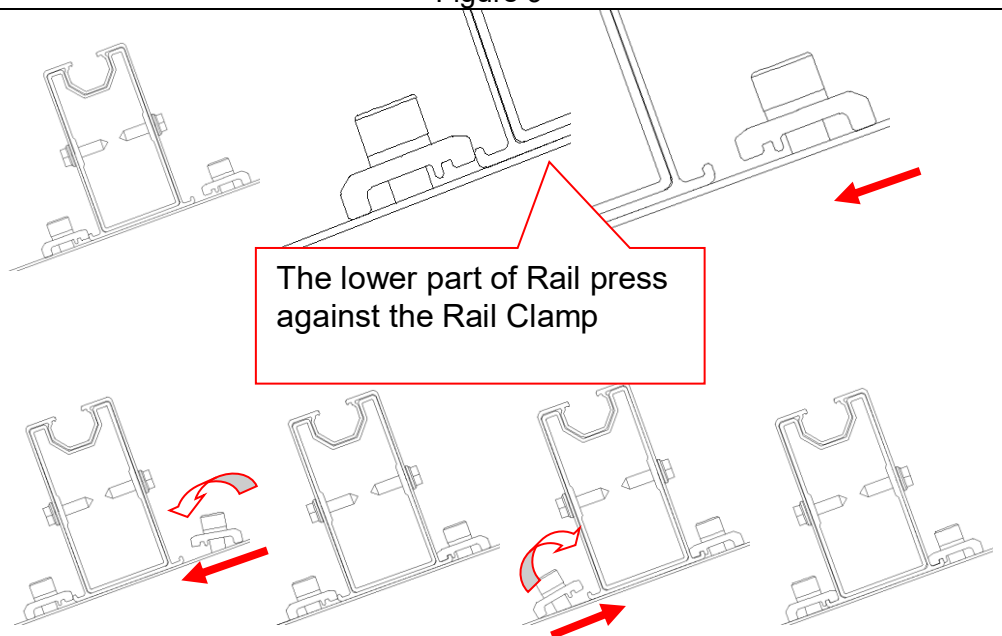

Figure 9

4.3.2 According to your plan, place TW Rail on the girder, make the lower part of Rail press against pre-assembled Rail Clamp II as shown in Figure 10.

Note: if the project doesn't have pre-assembled Rail Clamp II, please fix Rail Clamp II on each side of Rail on site.

4.3.3 Place the rails one by one on the planned position.



Figur 10

4.3.4 Repeat the above steps to install other rails. Make sure the rails in the same line aligned over same horizontal level. Ensure the distances of rails between two adjacent rows conforming to the engineering drawings and the end faces of all rails aligned.

Recommended Torque:
M8: 18~20 N•m

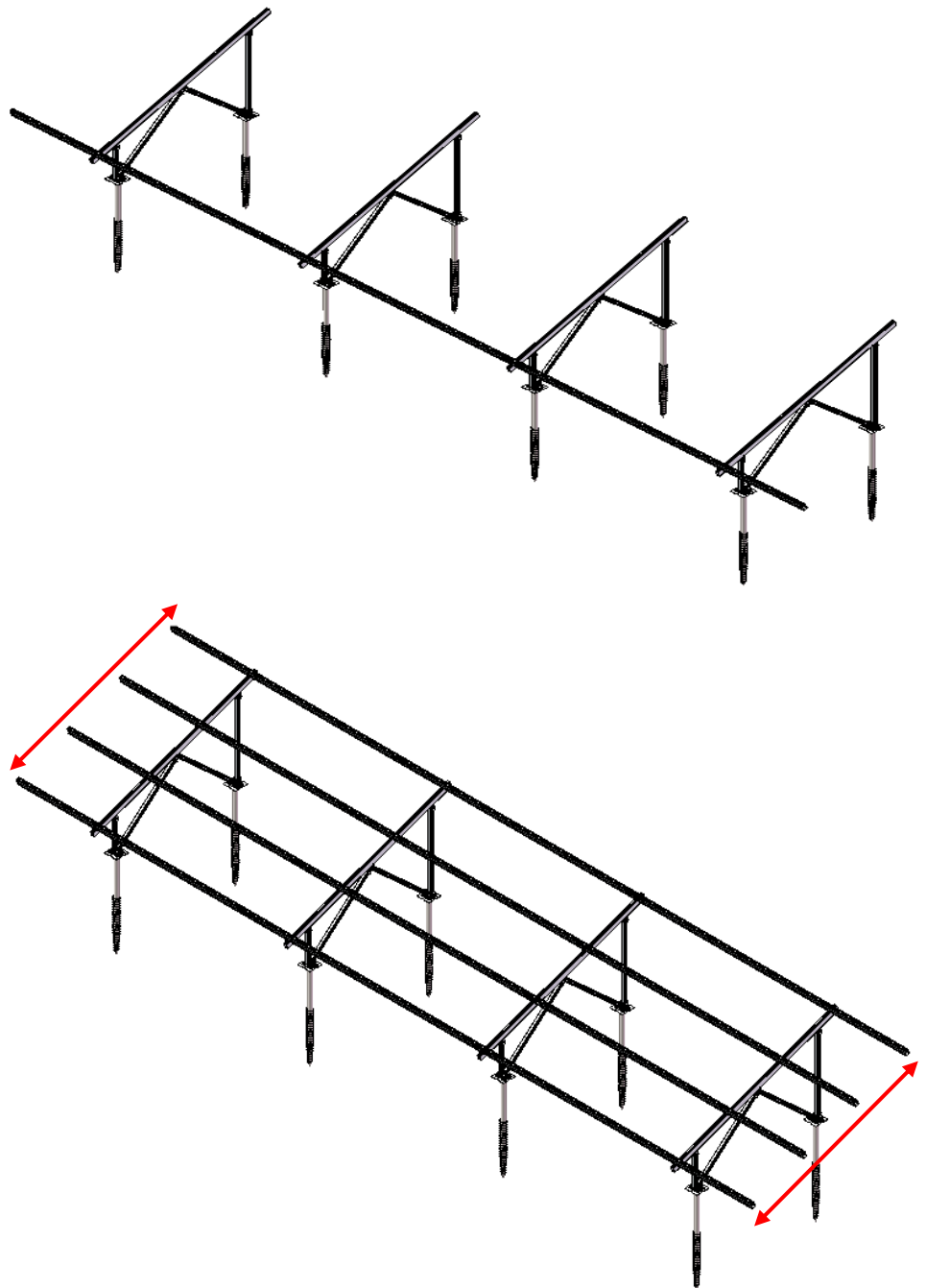

Figure 11

4.4 Angle AL Installation

4.4.1 According engineer plan, lightly lock Connector for Rectangular Tube on the rear leg of Support as shown in Figure 12. Insert M8*30 through the hole on Angel AL.

Lightly lock another Connector for Rectangular Tube on the next span rear leg and adjust its position to lock the Angel AL and make it be in tension status. Use Self-tapping screw ST6.3*22 to fix Connector for Rectangular Tube and fasten all bolts as shown in Figure 13.

Note:

The quantity, position and tilt direction need to comply with the requirement on engineer drawings.

Recommend torque:
M 8 bolt 18~20N.m

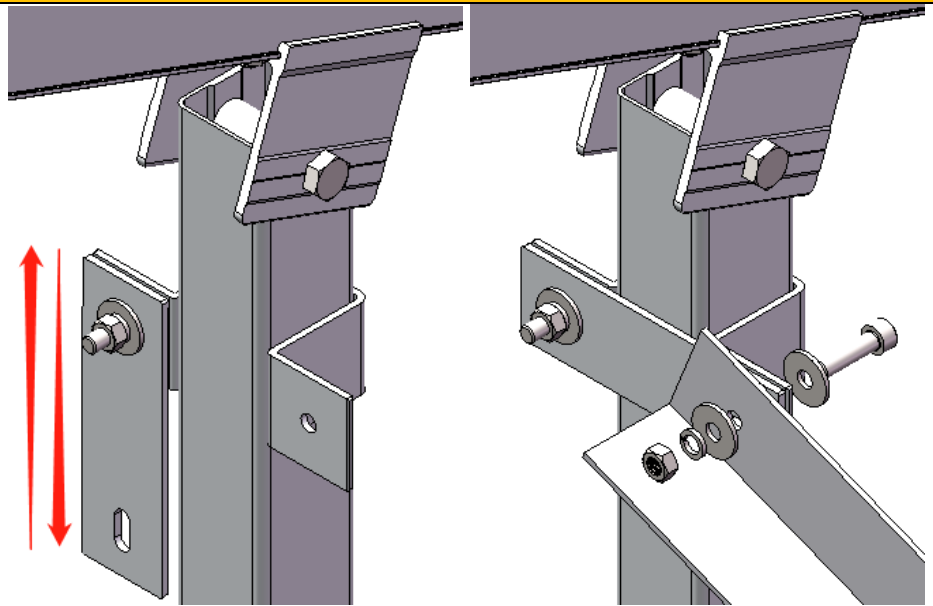

Figure 12

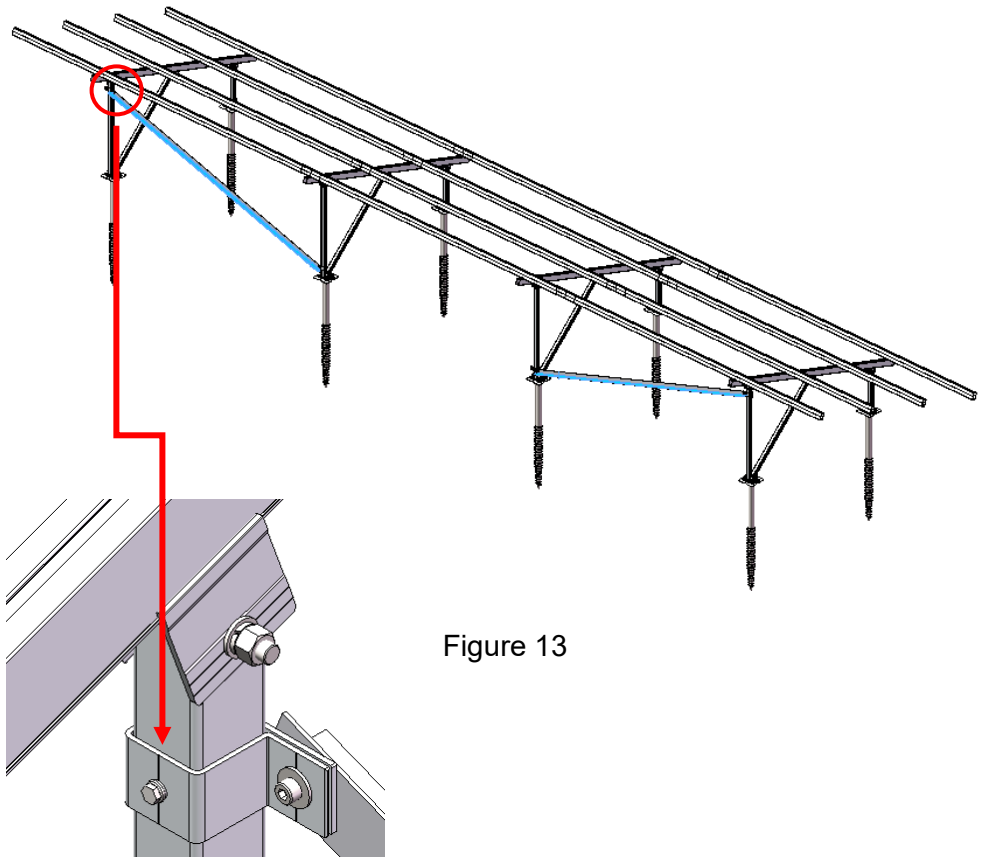
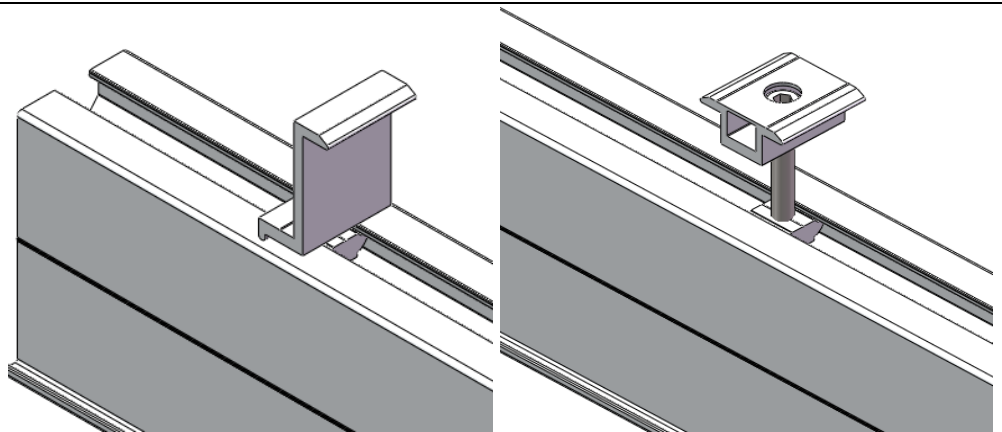

Figure 13

4.5 PV Modules Installation

4.5.1 Tilt the Inter Clamps with W-module into the channel of the Rail as shown in Figure 14.



4.5.2 It is suggested to install PV-Module from the left side, and use the End Clamp and Inter Clamp to fix it. Stretch a String as a reference to align PV-Module. Adjust the PV-Modules to make their outside faces are in a line in both portrait and landscape orientation.

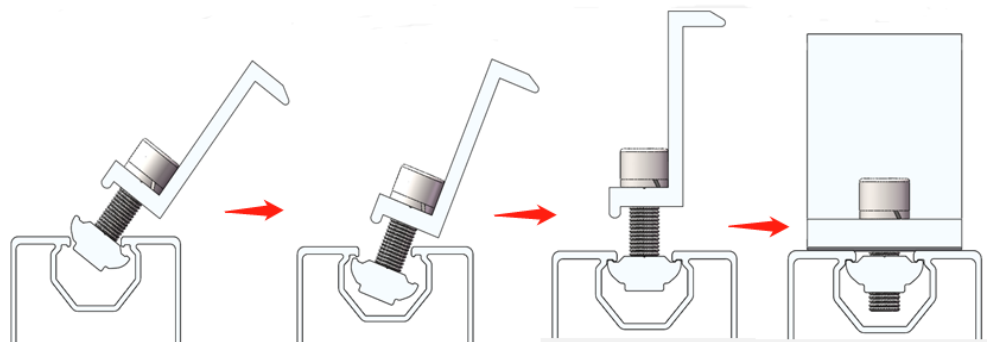

Figure 14

Recommended Torque:
M8: 13~14N•m

Ensure the PV modules aligned in both horizontal and vertical directions

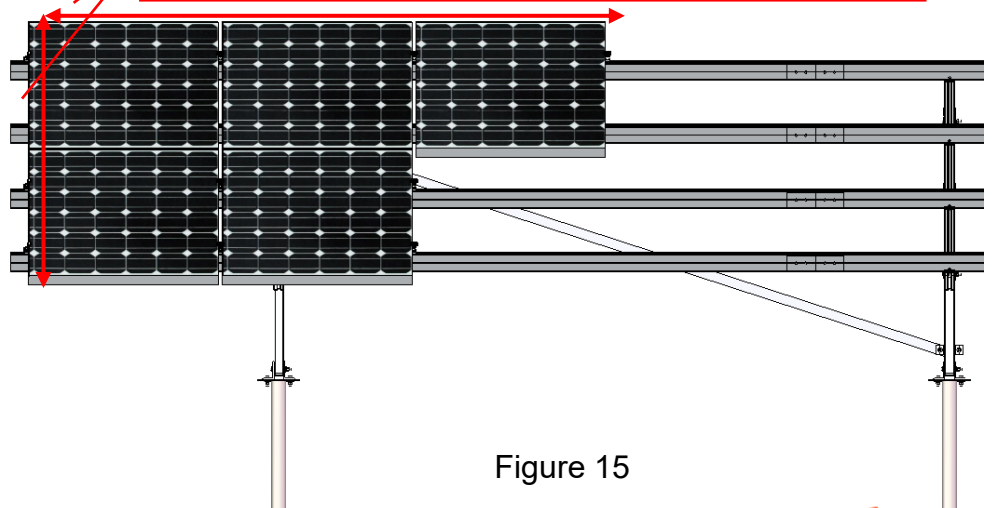

Figure 15

4.5.3 Fix the rest of PV-Module according to the sequence: from low to up, from left to right. Make the side faces of PV-Module tightly against Clamps as shown in Figure 18. Any adjacent side face of PV-Module keep the distance of 20mm, as shown in Figure 16.

Note:

Put an Inter Clamp at each side of PV-Module to keep the distance of 20mm and take them away after the PV-Module being fixed.

4.5.4 Now the installation of a single array is completed as shown in Figure 17.

Please recheck all bolts, and fasten them tightly.

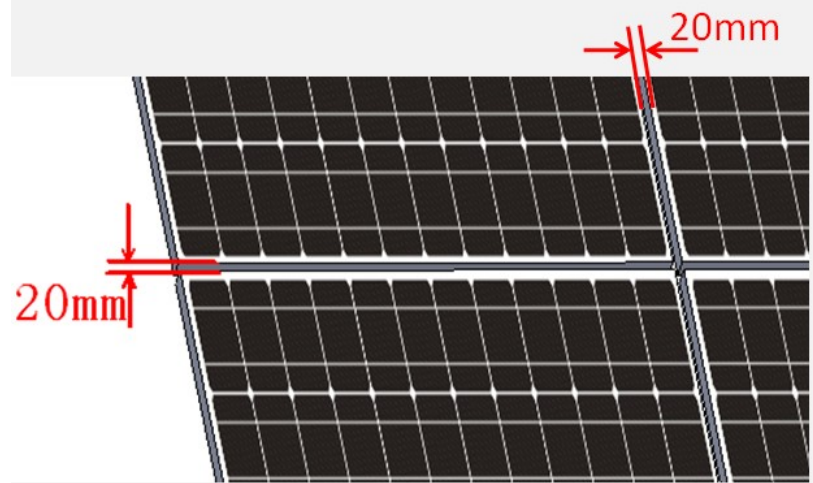

Figure 16

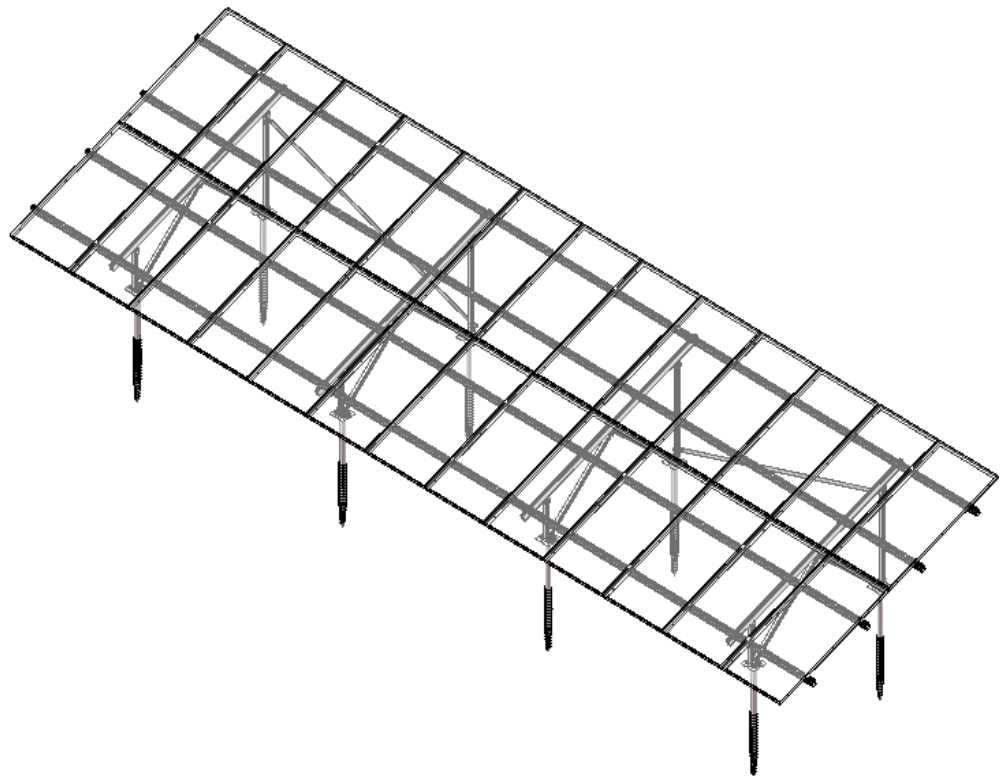

Figure 17